



Memories

Those little things

CARMEN
true tiles

Index

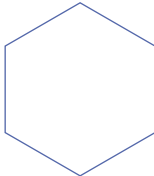
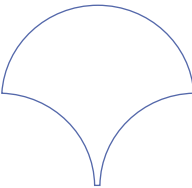
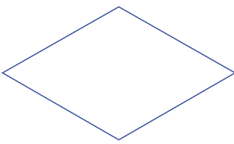
Índice

			
12x13,8 cm / 5"x5,5"	12x12,5 cm / 5"x5"	9,8x16,8 cm / 4,2"x6"	6,5x13 cm / 2"x5"
Pág. 16	Pág. 22	Pág. 28	Pág. 34

Shine / Brillo

Kisses	Smiles	Looks	Memories
---------------	---------------	--------------	-----------------



Shine crackled / Brillo craquelado

Dawn	Rain	Trip	Moments
-------------	-------------	-------------	----------------

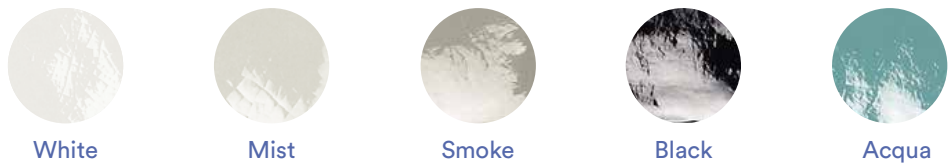

Carmen is a declaration of love to the true ceramic essence: small size products with a decorative vocation. Touch have recovered and updated ceramic classics typical of the industrial history and Mediterranean handicraft. Our aim is to offer a range of delicate and technically evolved products that adapt to the needs of any project. Carmen is APE Grupo's brand specialized in small size ceramic tiles.

Carmen es una declaración de amor a la verdadera esencia cerámica: productos de pequeño formato con vocación decorativa. Hemos recuperado y actualizado clásicos cerámicos propios de la historia industrial y artesana mediterránea. El objetivo es ofrecer una serie de productos delicados y técnicamente evolucionados que se adapten a las necesidades de los proyectos. Carmen es la marca de APE Grupo especializada en cerámica de pequeño formato.

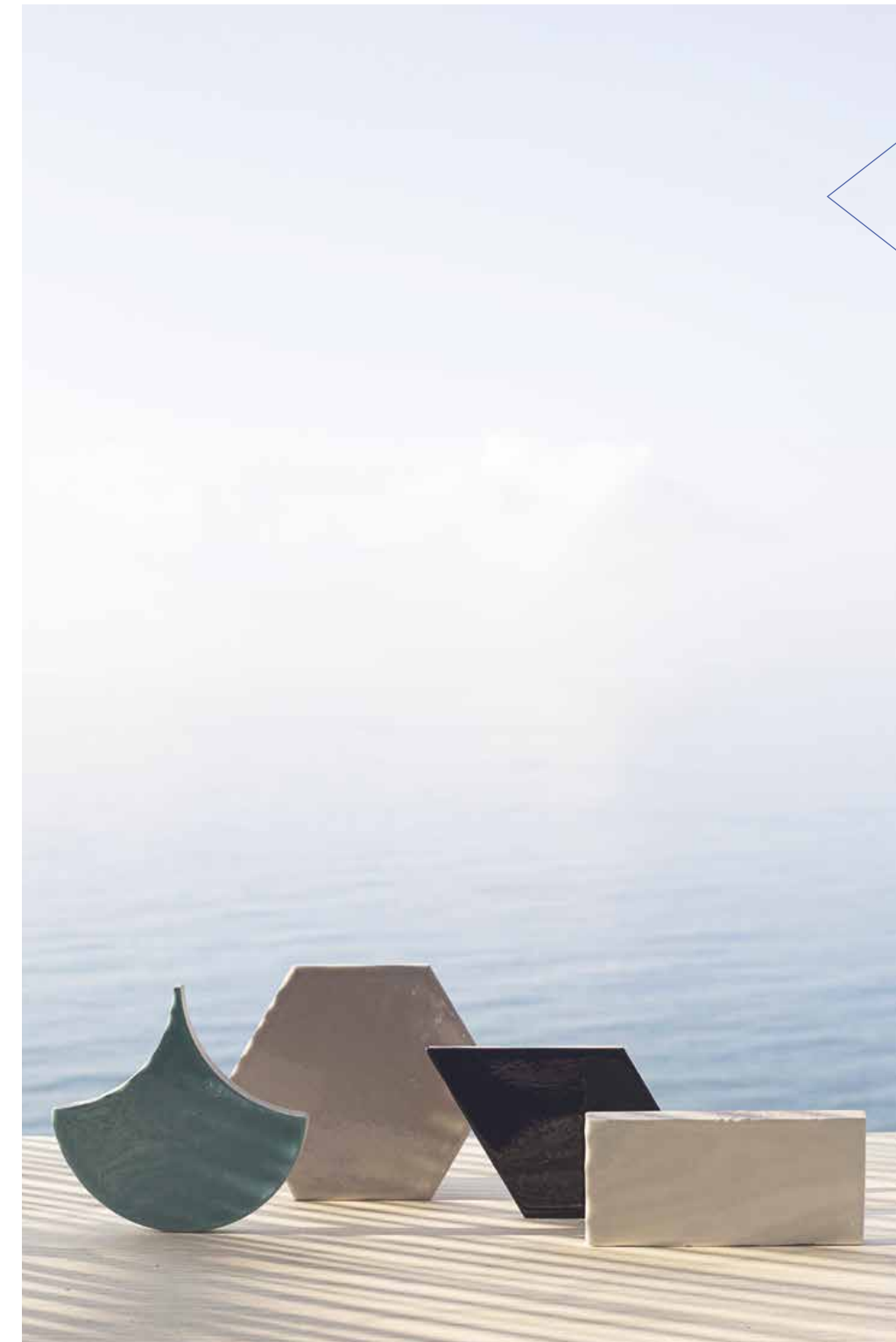
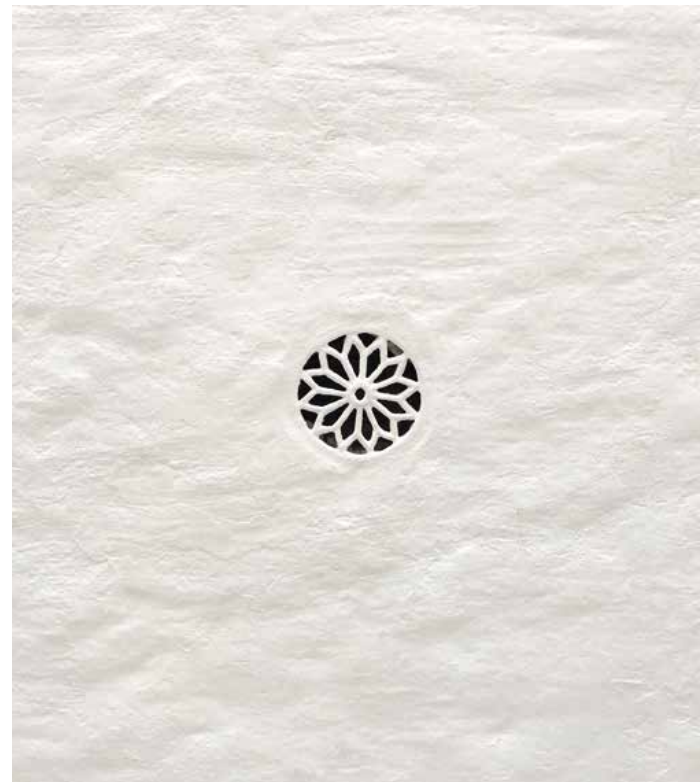

True tiles

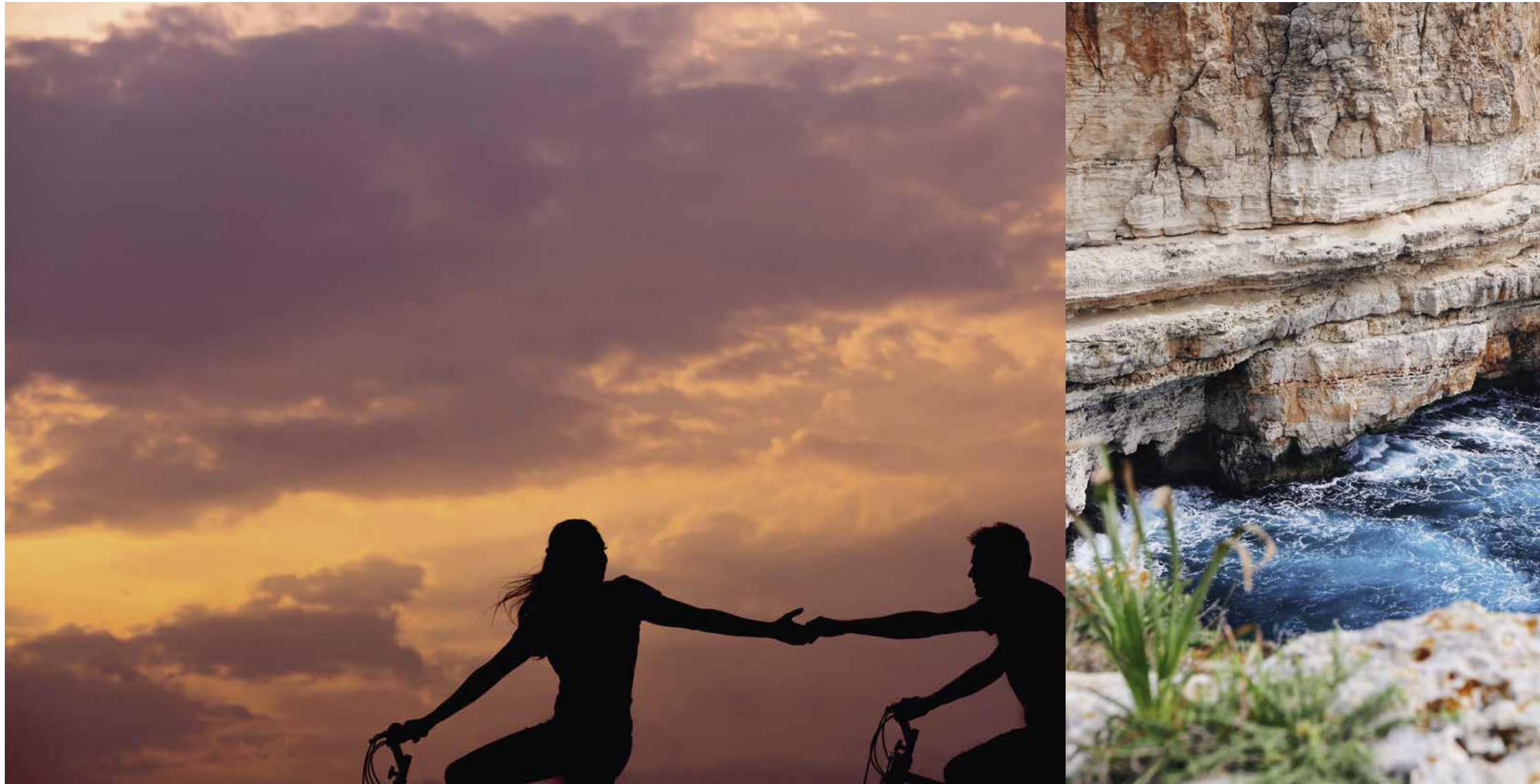

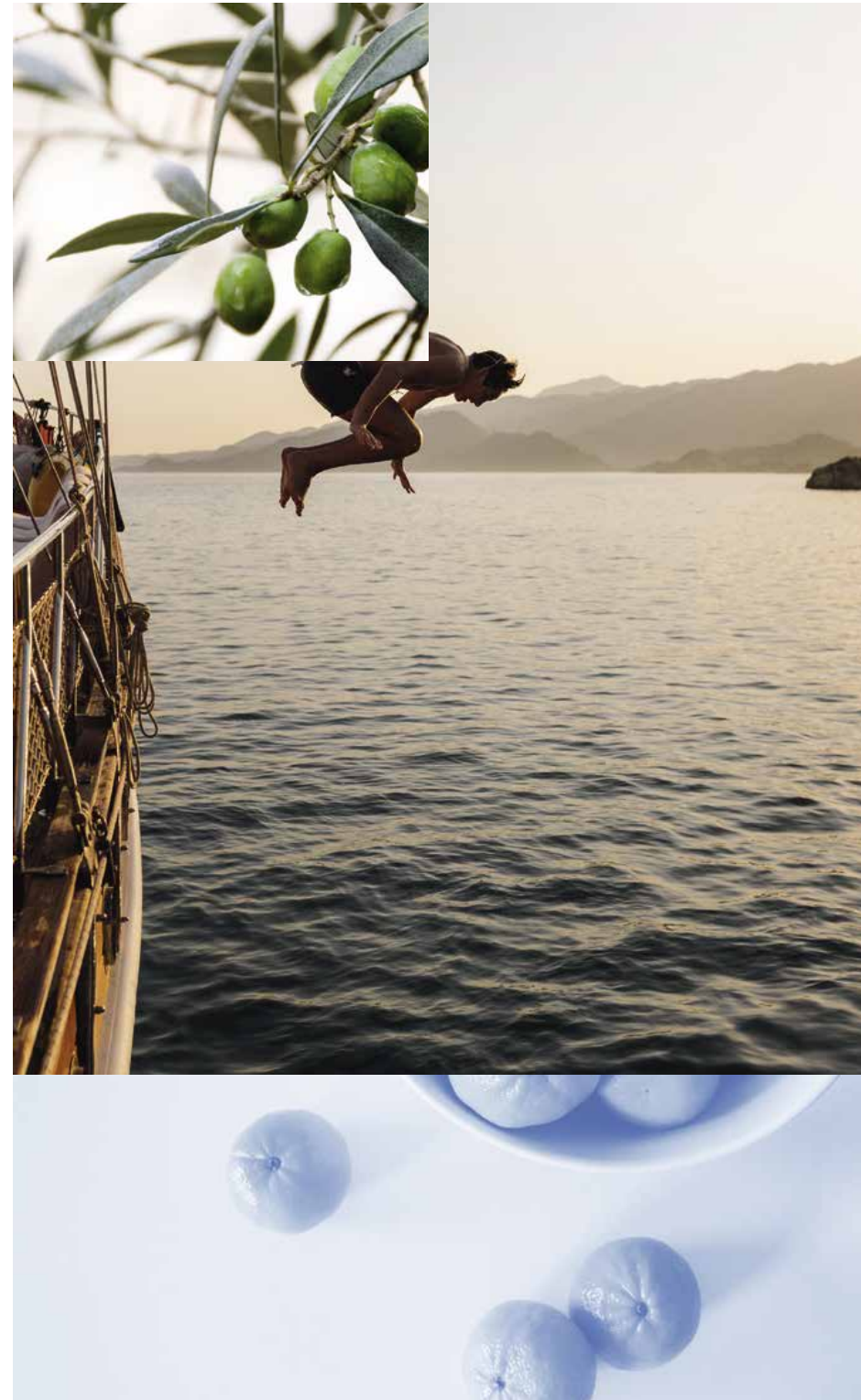

Memories

Those little things

Sharing a family meal, having a laugh with friends, admiring the sunset from the beach, enjoying a freshly squeezed orange juice, treating yourself to a twenty-minute siesta... In the Mediterranean we're happy with the small things in life; moments that are special simply because you're with a person you care about.

Because sometimes the best things in life come in small packages. That's why Carmen is launching Memories, a collection that embraces the true Mediterranean spirit in an even smaller format. True tiles!

Compartir una comida en familia, una risa entre amigos, disfrutar la puesta de sol desde la playa, un zumo de naranja recién exprimido, regalarte una siesta de 20 minutos... En el Mediterráneo somos felices con pequeñas cosas, momentos que son especiales simplemente porque estás con una persona que te importa.

Porque a veces lo mejor de la vida viene en envase pequeño. Por eso en Carmen lanzamos Memories, una colección que condensa el verdadero espíritu mediterráneo en un formato todavía más pequeño. ¡Auténticos True Tiles!

Ceramics with a Mediterranean spirit

Cerámica con espíritu mediterráneo

Here at Carmen we like to stick to our roots. And tiles are an essential part of them. We've retrieved four classic tile designs that directly connect with the history of tiles in an even smaller format. Small in appearance, big in emotion.



En Carmen nos preocupamos por mantener vivas nuestras raíces. Y la cerámica es una parte esencial de ellas. Recuperamos cuatro clásicos del diseño cerámico que conectan directamente con la historia cerámica en un formato aún más reducido. Pequeño en apariencia, grande en emoción.



→
In the Mediterranean region, the olive harvest begins in autumn. Olive oil is treasured worldwide for its properties and taste.

En la región mediterránea, la recogida de la aceituna comienza en otoño. El aceite de oliva es valorado en todo el mundo por sus propiedades y sabor.



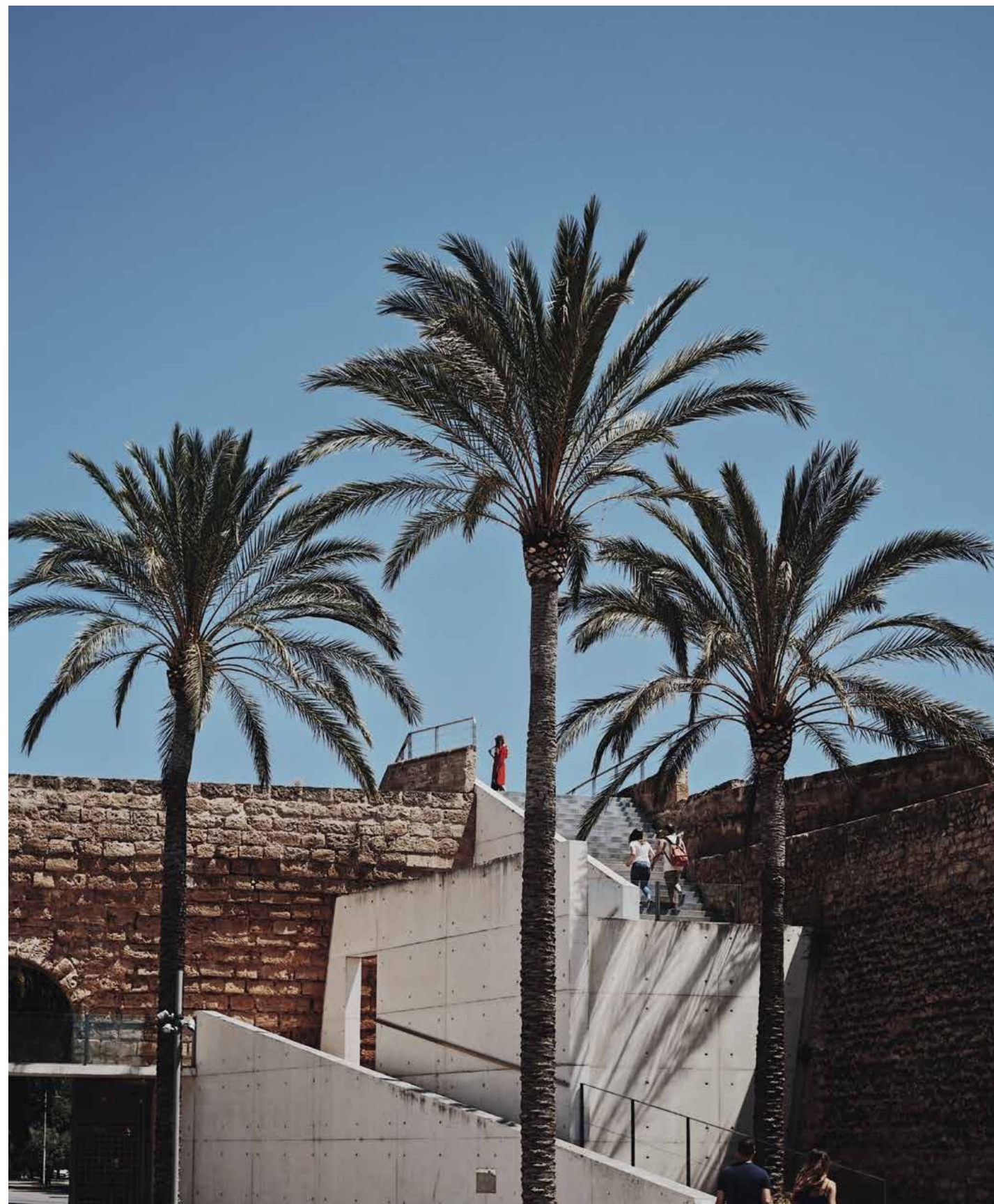

Not perfect and perfect at the same time

Imperfecto y perfecto al mismo tiempo

Memories es una colección especial donde usamos técnicas de fabricación reintroducidas de los sistemas artesanos. Por un lado, está compuesta de versiones más pequeñas de los formatos clásicos cerámicos. Además utilizamos un sistema de bicocción que nos permite reproducir degradados de color en la superficie y craquelados a voluntad. En Carmen hemos conseguido reproducirlo sin perder ninguna de las propiedades mecánicas del material. ¡Pura esencia cerámica!

Memories is a special collection where we use production techniques reintroduced from handicrafts systems. On the one hand, it's composed of smaller versions of the classic tile formats. We also use a double firing system that allows us to reproduce colour gradients on the surface and with a crackle glazed effect when desired. At Carmen we've managed to reproduce it without losing any of the mechanical properties of the material. Pure ceramic essence!



Es Baluard Museum, Majorca (Spain).
Es Baluard Museu, Mallorca (España).



Detalle del craquelado de Dawn White.
Craquelé detail of Dawn White.





12

Memories: those little things



13

Carmen True Tiles

The background of the left page is a dark blue, textured surface. A white, root-like pattern, resembling tree roots or a network of fibers, is visible, extending from the top and right towards the center. The texture is grainy and organic.

/true tile/:
a ceramic tile proud of its roots.

/true tile/:
una baldosa cerámica orgullosa de sus raíces.

Memories

Kisses & Dawn

12x13,8 cm / 5"x5,5"

Like many of the classic tiles, the origins of the hexagon can be found in the Mudéjar architecture of the twelfth and sixteenth centuries. It was during the Modernist period when this format was revived with icons such as the Gaudi tile. At Memories we've retrieved this format in a smaller version that gives it a truly unique charm.

Como muchos de los clásicos cerámicos, los orígenes del hexágono podemos encontrarlo en la arquitectura mudéjar de los siglos XII y XVI. Es durante el modernismo cuando se actualiza este formato con iconos como la loseta Gaudí. En Memories recuperamos este formato en una versión más reducida que le da un encanto único.



*Tile displayed at actual size
Baldosa reproducida a tamaño real

Kisses / Dawn

12x13,8 /
5"x5,5"



KISSES WHITE
12X13,8 / 5"X5,5"
P70/M



DAWN WHITE
12X13,8 / 5"X5,5"
P71/M



KISSES MIST
12X13,8 / 5"X5,5"
P70/M



DAWN MIST
12X13,8 / 5"X5,5"
P71/M



KISSES SMOKE
12X13,8 / 5"X5,5"
P70/M

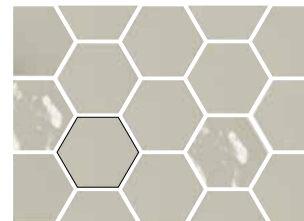

DAWN SMOKE
12X13,8 / 5"X5,5"
P71/M



KISSES NIGHT
12X13,8 / 5"X5,5"
P70/M



DAWN NIGHT
12X13,8 / 5"X5,5"
P71/M



KISSES ACQUA
12X13,8 / 5"X5,5"
P70/M



DAWN ACQUA
12X13,8 / 5"X5,5"
P71/M



Shine / Brillo



Shine crackled / Brillo craquelado



KISSES SMOKE 12X13,8 - KOEN CARAMELLO MATT RECT. 20X120



KISSES MIST 12X13,8

Smiles & Rain

12x12,5 cm / 5" x 5"

Fish scale tiling is another of the classic icons of nineteenth-century industrial design. One of the greatest influences on Modernism was nature. Motifs of flowers, vegetation and animals were constantly depicted in designs. A perfect example: the fish scale tiles that at Memories we've retrieved with a smaller format.

La escama cerámica es otro de los iconos clásicos del diseño industrial del siglo XIX. Una de las grandes influencias para el modernismo era la naturaleza. En sus decoraciones se reproducen constantemente motivos de flores, vegetación y animales. Una buena muestra de ello son las baldosas cerámicas en forma de escama de pez que en Memories recuperamos con un formato más reducido.



*Tile displayed at actual size
Baldosa reproducida a tamaño real

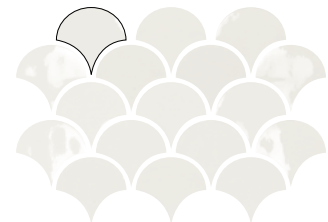

SMILES WHITE
12X12,5 / 5"X5"
P66/M

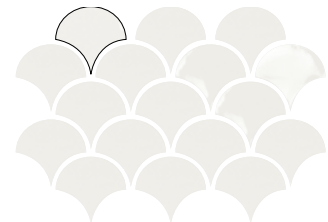

RAIN WHITE
12X12,5 / 5"X5"
P67/M

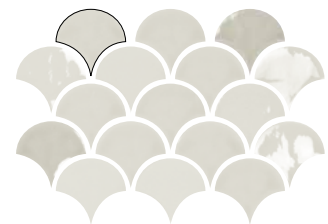

SMILES MIST
12X12,5 / 5"X5"
P66/M

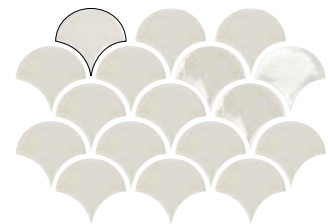

RAIN MIST
12X12,5 / 5"X5"
P67/M

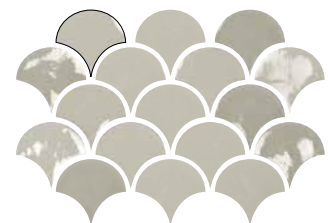

SMILES SMOKE
12X12,5 / 5"X5"
P66/M

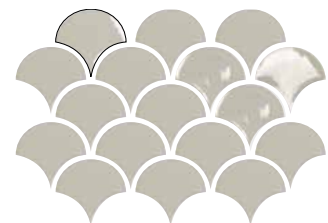

RAIN SMOKE
12X12,5 / 5"X5"
P67/M

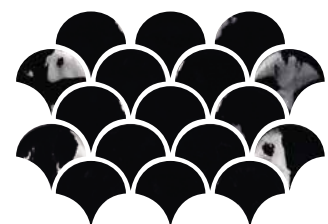

SMILES NIGHT
12X12,5 / 5"X5"
P66/M

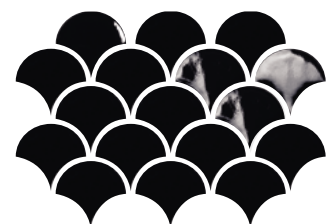

RAIN NIGHT
12X12,5 / 5"X5"
P67/M

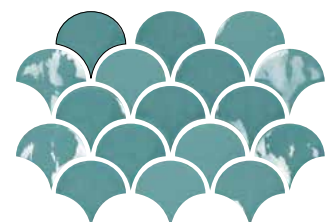

SMILES ACQUA
12X12,5 / 5"X5"
P66/M

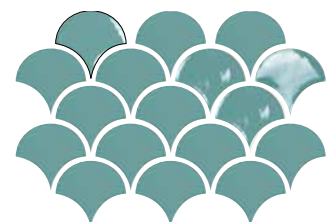

RAIN ACQUA
12X12,5 / 5"X5"
P67/M



Shine / Brillo



Shine crackled / Brillo craquelado



RAIN ACQUA 12X12,5 / WABI WHITE LAP. RECT. 60X60



SMILES MIST 12X12,5

Looks & Trip

9,8x16,8 cm / 4,2"x6"

The rhombus is one of the most special shapes in tiling, as it creates a unique effect. It's purely geometric, but it adds movement. At Memories we've given a twist to this format with a small-scale collection with a graphic development inspired by traditional enamels.

El rombo es uno de los paralelogramos más especiales en baldosas, ya que genera un efecto único. Es puramente geométrico, pero aporta movimiento. En Memories le damos una vuelta de tuerca a este formato con una colección en formato reducido y con un desarrollo gráfico inspirado en los esmaltes tradicionales.



*Tile displayed at actual size
Baldosa reproducida a tamaño real

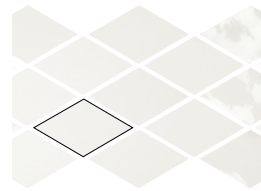

LOOKS WHITE
9,8X16,8 / 4,2X6"
P68/M

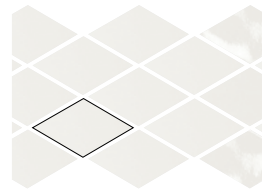

TRIP WHITE
9,8X16,8 / 4,2X6"
P69/M

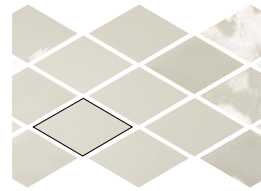

LOOKS MIST
9,8X16,8 / 4,2X6"
P68/M

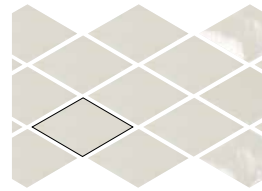

TRIP MIST
9,8X16,8 / 4,2X6"
P69/M

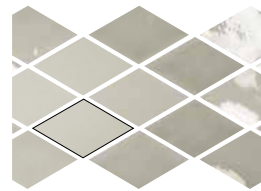

LOOKS SMOKE
9,8X16,8 / 4,2X6"
P68/M

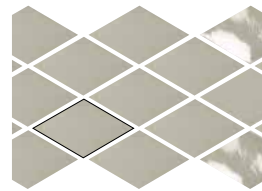

TRIP SMOKE
9,8X16,8 / 4,2X6"
P69/M

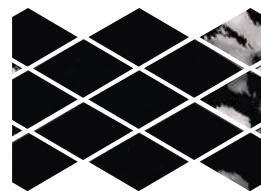

LOOKS NIGHT
9,8X16,8 / 4,2X6"
P68/M

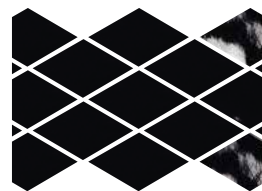

TRIP NIGHT
9,8X16,8 / 4,2X6"
P69/M

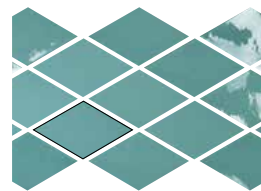

LOOKS ACQUA
9,8X16,8 / 4,2X6"
P68/M

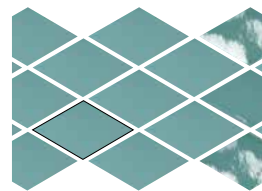

TRIP ACQUA
9,8X16,8 / 4,2X6"
P69/M



Shine / Brillo



Shine crackled / Brillo craquelado



LOOKS NIGHT 9,8X16,8

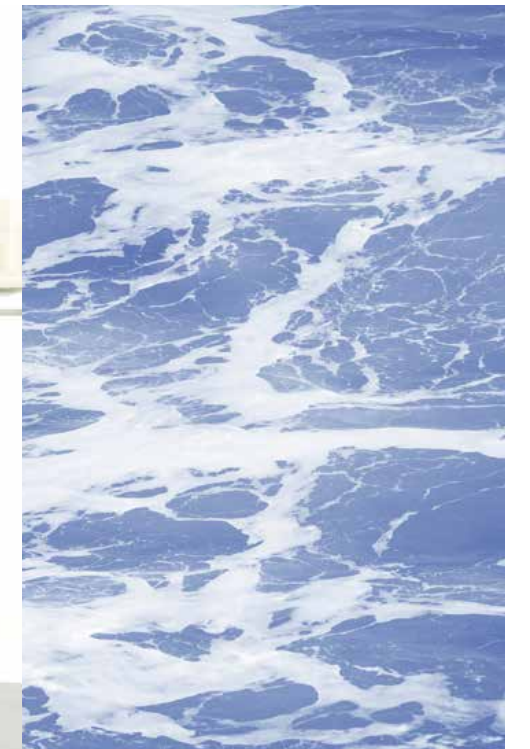
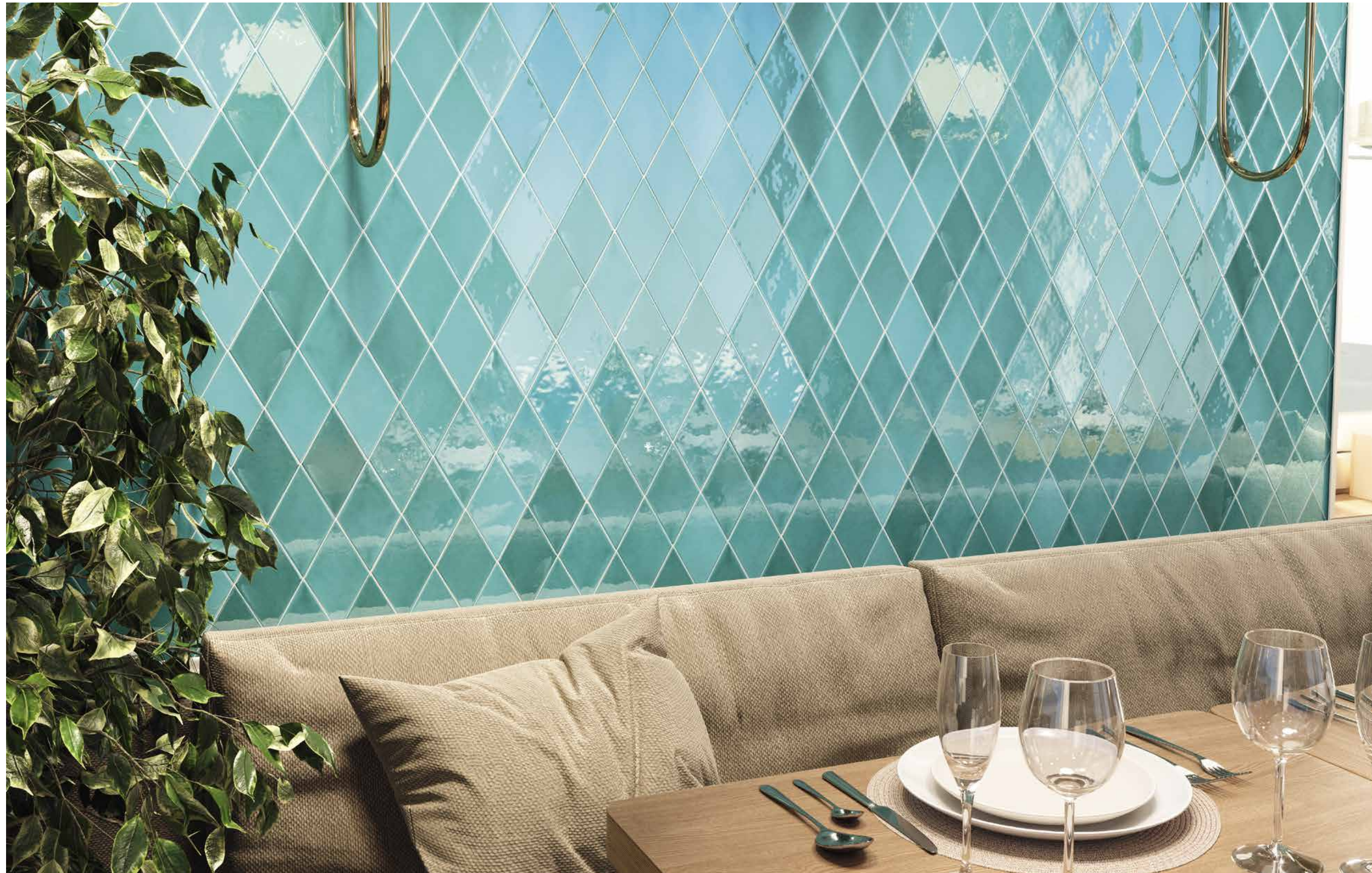

LOOKS ACQUA 9,8x16,8

Memories & Moments

6,5x13 cm / 2"x5"

One of the most classic formats of ceramic design. Although this is a format that has been around for centuries, it was with the arrival of the underground that it became an authentic icon of urban life. As Carmen we've retrieved this iconic design in its purest version, both in more perfected finishes and with the waves and imperfections of manual finishes, which give the design an unparalleled beauty.

Uno de los formatos más clásicos del diseño cerámico. Aunque es un formato que ha existido desde hace siglos, fue con la llegada del metro cuando se convirtió en un verdadero icono de la vida urbana. En Carmen hemos recuperado este icono del diseño en su versión más pura, tanto en acabados más perfectos como con las ondas e imperfecciones propias de los acabados manuales, que le otorgan una belleza única al diseño.



*Tile displayed at actual size
Baldosa reproducida a tamaño real

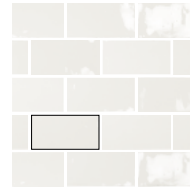

MEMORIES WHITE
6,5X13 / 2"X5"
P72 / M



MOMENTS WHITE
6,5X13 / 2"X5"
P73 / M



MEMORIES MIST
6,5X13 / 2"X5"
P72 / M



MOMENTS MIST
6,5X13 / 2"X5"
P73 / M



MEMORIES SMOKE
6,5X13 / 2"X5"
P72 / M

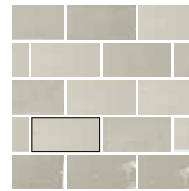

MOMENTS SMOKE
6,5X13 / 2"X5"
P73 / M



MEMORIES NIGHT
6,5X13 / 2"X5"
P72 / M

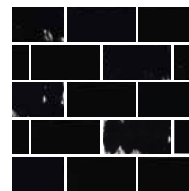

MOMENTS NIGHT
6,5X13 / 2"X5"
P73 / M

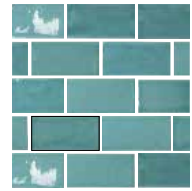

MEMORIES ACQUA
6,5X13 / 2"X5"
P72 / M

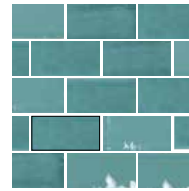

MOMENTS ACQUA
6,5X13 / 2"X5"
P73 / M



Shine / Brillo



Shine cracked / Brillo craquelado

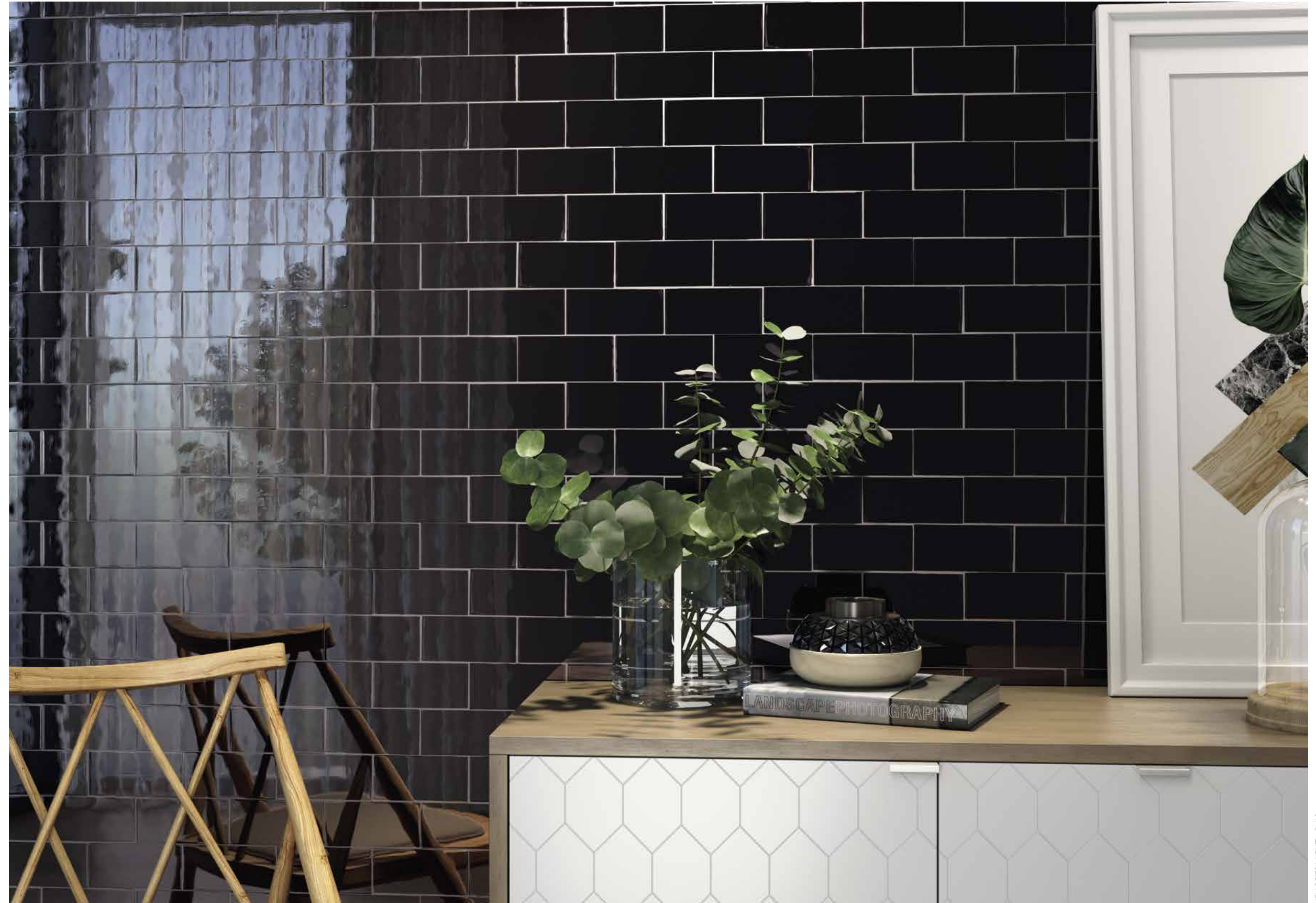

MEMORIES NIGHT 6,5X13



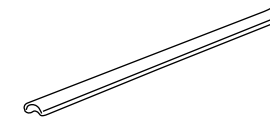

EDGE STICK MEMORIES
1,5X30 / 0,6"X12" K18/P

Características técnicas · technical characteristics

PB PASTA BLANCA/WHITE BODY/PÂTE BLANCHE

B BRILLO/SHINE/BRILLANT

THICKNESS 0,3" / ESPESOR 9MM

V REVESTIMIENTO/WALL TILE/FAÏENCE

V3 VARIACION MODERADA/MODERATE VARIATION / MODÉRÉE VARIATION

Formato pzas	Pzs/caja Tiles/box Pièces/boîte	M2/caja Sqm/box Mètres/boîte	Kg/caja Kg/box Kg/boîte	Cajas/pallet Boxes/pallet Boîtes/palette	M2/pallet Sqm/pallet Mètres/palette	Kg/pallet Kg/pallet Mètres/palette
12X12,5	44	0.33	5.51	78	25.74	430
12X13,8	38	0.48	6.25	102	49.06	637
6,5X13	60	0.5	7.46	100	50	746
9,8X16,8	62	0.5	6.75	84	42	567

CARMEN

true tiles

Ciudad del Transporte
C/ Luxemburgo, 46
12006 Castellón (Spain)

Ape Italia Srl
Via Carazzoli, n° 17-19
Fiorano Modenese (Modena)
Italia

T. +34 964 340 434
apegrupo@apegrupo.com
apegrupo.com

The reproduction of the colors is approximate. Carmen reserves the right to alter or amend the products here stated.
La reproducción de los colores es aproximada. Carmen se reserva el derecho de alterar o modificar los productos aquí relacionados.

Price codes and product codes should be checked, since there may be typographical errors. Touch always recommend consulting the Touchbsite as the products could undergo price code, format or packing changes.
Los códigos de precios y referencias deben verificarse ya que puede haber errores tipográficos. Es recomendable consultar la Touchb ya que cualquier producto de este catálogo puede sufrir cambios en códigos de venta, formatos o packing.

On the Touchbsite you can also find the technical specifications, installation suggestions, merchandising elements and a variety of room scene pictures for each of the inspirations.
En la Touchb también pueden consultar las características técnicas, consejos de colocación , elementos de merchandising o los diversos ambientes de cada una de las colecciones.